

# Dell™ 3100MP e

---

Dell .

---

[Dell](#)



---

© 2001 Coretronic Corporation.

© 2002 Dell Computer Corporation. .

Dell Computer Corporation

: *Dell DELL* Dell Computer Corporation; Dell *DELL* Dell Computer Corporation *DLP Texas Instruments* Texas Instruments Corporation *Microsoft Windows* Microsoft Corporation; *Macintosh* Apple Computer, Inc.

Dell Computer Corporation

---

Dell Dell

Dell Dell

---

March 2002 Rev. A00

: Dell™ 3100MP



:

- n 30
  - n
  - 3 .
  - n II .
  - n
  - n .
  - n
  - n .
  - n
  - n .
  - n
  - n .
  - n .
  - n .
  - n .
-

# : Dell™ 3100MP

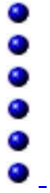

- Single chip 0.7" Texas Instruments DLP™
- XGA 1024 x 768
- 3.5 (1.6 .)
- 1000 ANSI Lumens
- 1024 x 768 NEW
- P-VIP 130
- Macintosh®
- NTSC, NTSC4.43, PAL, PAL-M, PAL-N, SECAM, HDTV (1080i, 720P, 576P, 480i/P)
- 
- DVI-I
- High definition TV
- (OSD)
- (keystone correction)
- 
- 

[Dell](#)

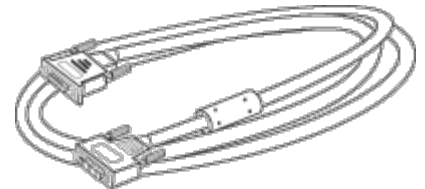
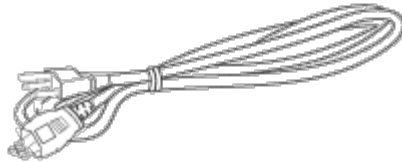
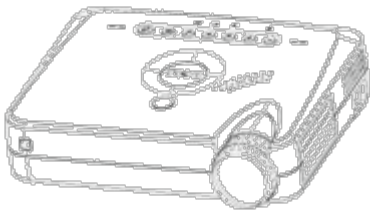

D-sub DVI-I



S-Video

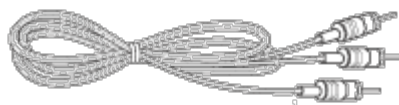

RCA Audio



Composite Video

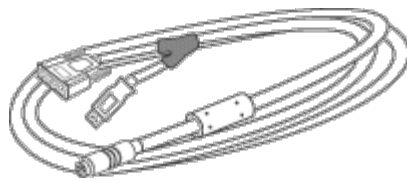
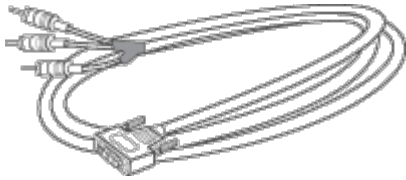

DVI-I  
HDTV/Component

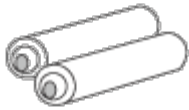

2



*Dell 3100MP*

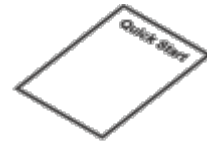

*Quick Start Dell 3100MP*

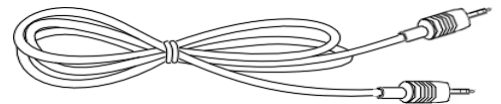
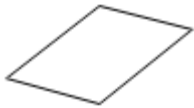

*Dell 3100MP*

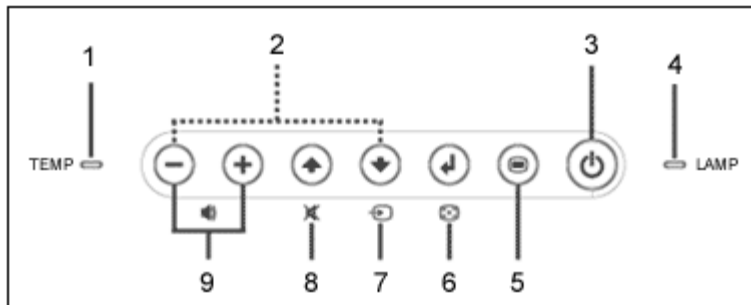

1	
2	
3	/
4	
5	
6	enter

7	
8	
9	

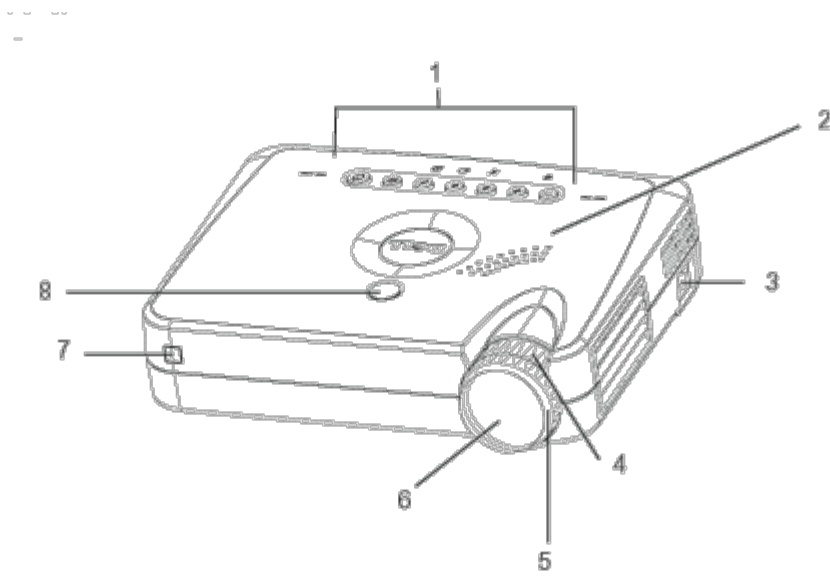

1	
2	
3	
4	/
5	
6	/
7	
8	

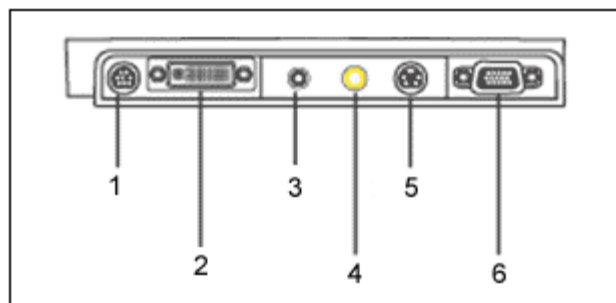

1	
2	/HDTV

3	
4	
5	S-video
6	-

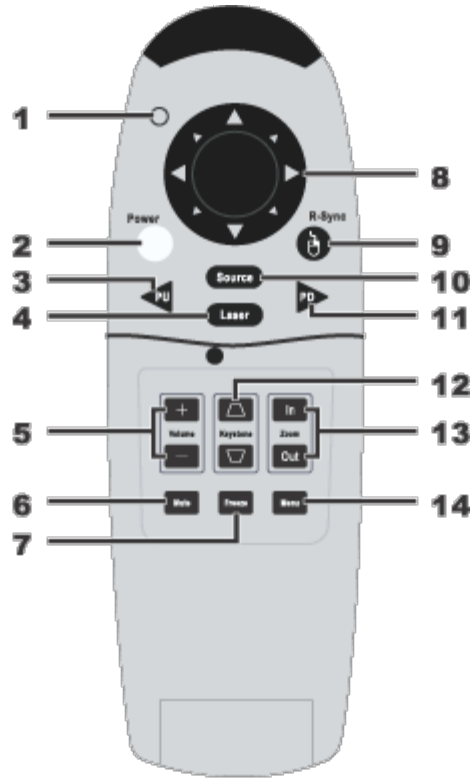

1	
2	/
3	PU ( )
4	
5	
6	
7	
8	
9	
10	
11	PD ( )
12	
13	/
14	

 : Class II .



: :- . *Quick Start Dell 3100MP.*

.

---

---

# : Dell™ 3100MP Projector

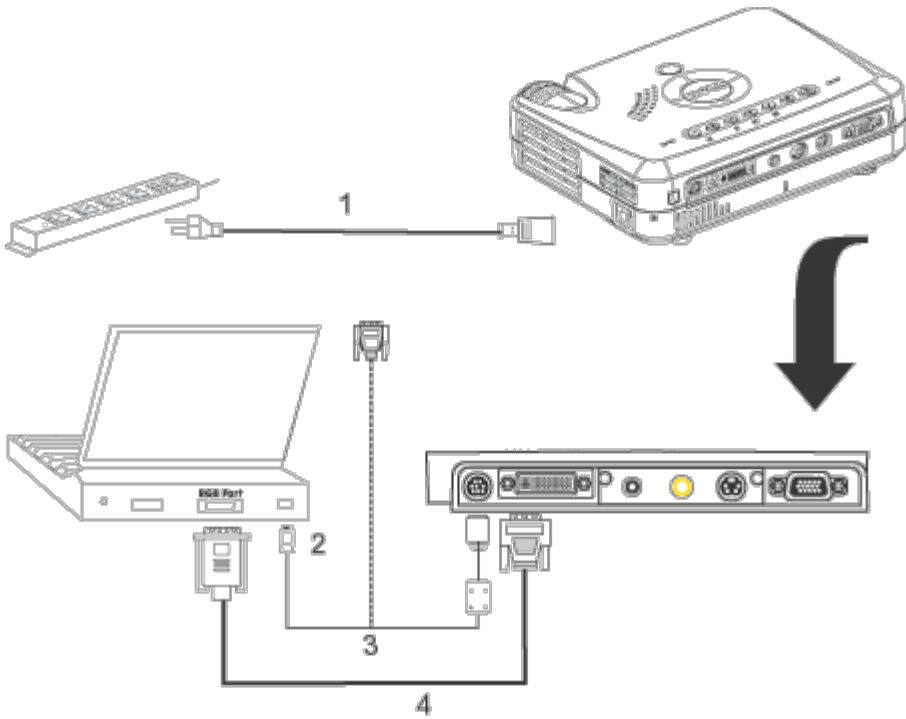

1	
2	USB
3	remote mouse Y-cable
4	D-sub to DVI-I cable

/



- 1.
2. D-sub DVI-I /
3. / 5 LAMP 20 LAMP
4. ( , )

- No Signal - check video cable ( ) D-sub DVI-I
- Source \_



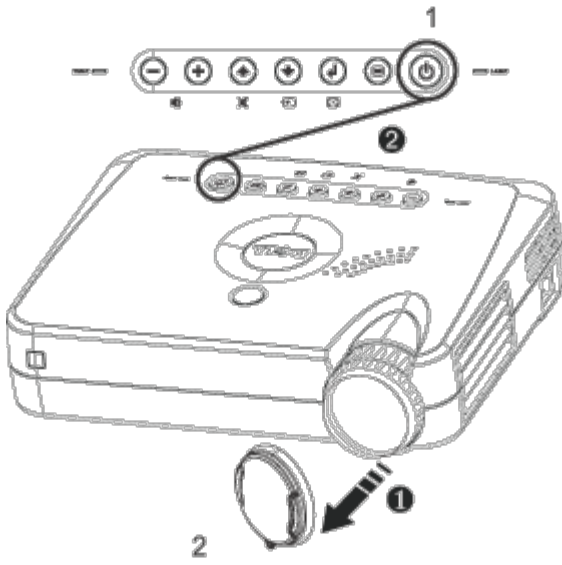

1	/
2	

1. / Power off the lamp?() OSD
2. / 30
- 3.
4. LAMP
5. TEMP [Dell](#).
6. / Power off the lamp? () 5

:

1. Elevator ()
- 2.
- 3.

:

1. Elevator ()
- 2.

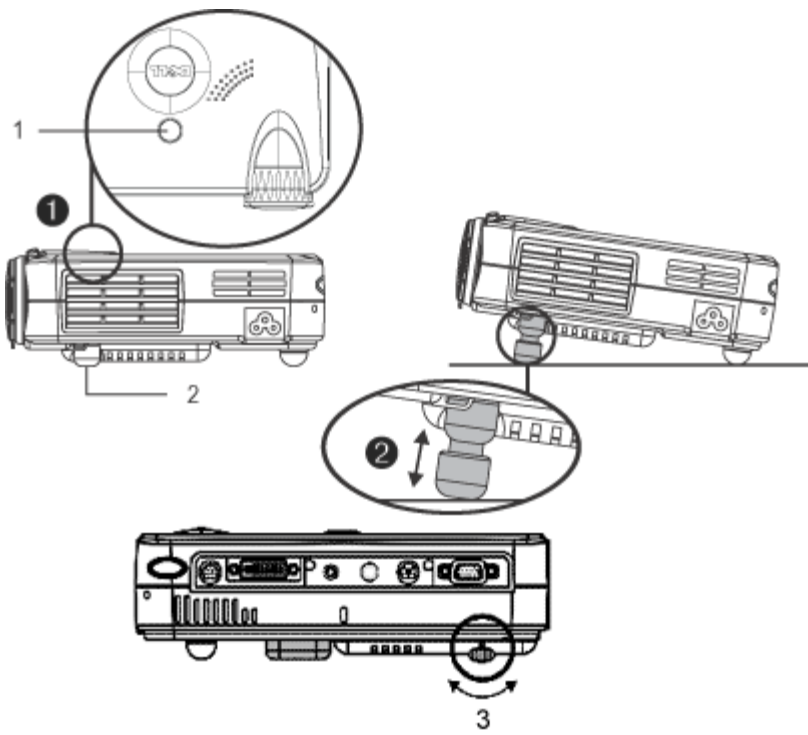

1	
2	
3	



: T

- 1. /
- 2. 3.3 39.4 ( 1 12 )

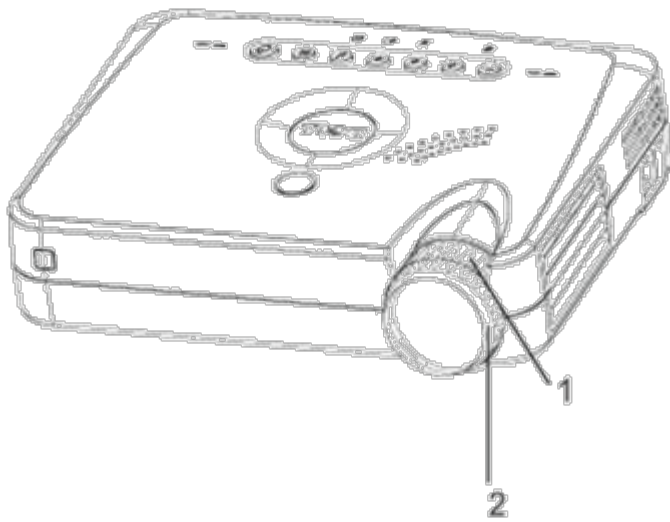

1	/
2	

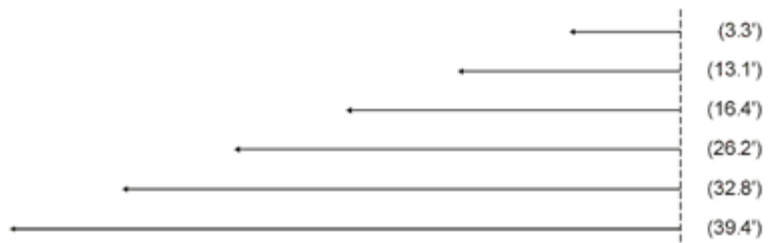
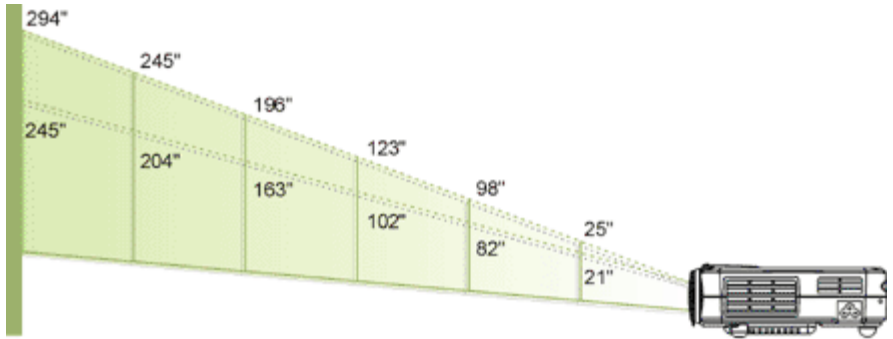

	25"	98"	123"	196"	245"	294"
0	21"	82"	102"	163"	204"	245"
( X )	20.0"X15.0	78.4"X58.8"	98.4"X73.8"	156.8"X117.6"	196"X147"	235.2"X176.4"
( X )	16.8X12.6"	65.6"X49.2"	81.6"X61.2"	130.4"X97.8"	163.2"X122.4"	196.0"X147.0"
	3.3'	13.1'	16.4'	26.2'	32.8'	39.4'
* *						

! Replacement suggested! ( ) :

 : 30  
:

- 1.
2. 30
3. ( )
- 4.
- 5.
6. 1 5
7. Lamp Reset [Management](#)
8. Dell Dell

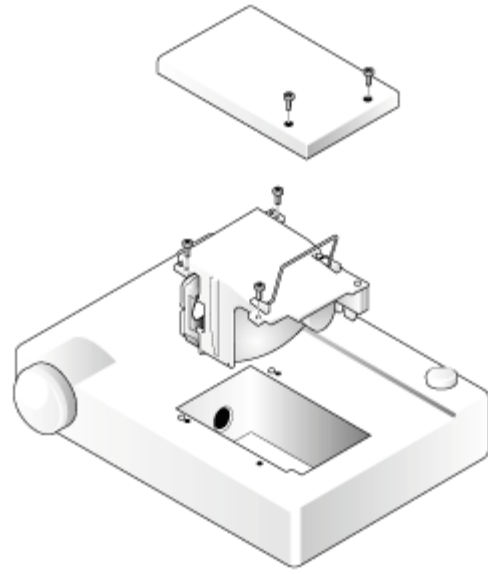

!!!

---

---

# : Dell™ 3100MP



Power (/)



Source

 RGB, Digital RGB, S-video, composite.

Resync ()



R-Sync [OSD](#)

Menu ()



Four Directional Select Keys ( 4 )



Mute ()



Volume () + / -

/.

Keystone () + / -

( ± 16 )

Enter



- 
- : R-Sync .

- Enter .
- [OSD](#)

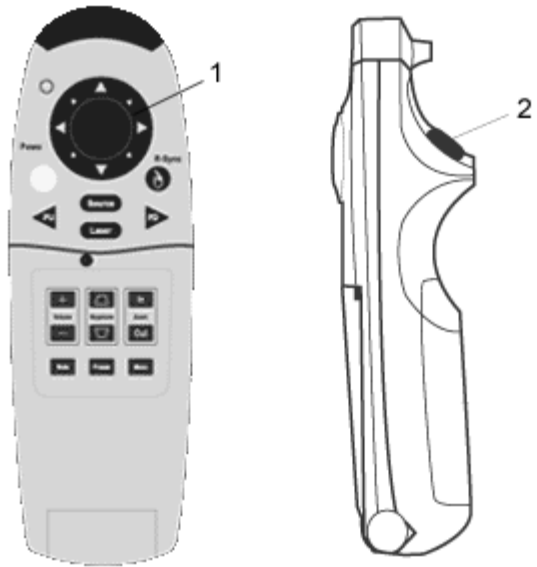

1	
2	Enter
3	

Power (/)

"L."

Source

Source RGB, Digital RGB, S-video composite .

Resync ()

R-Sync

R-Sync .

Laser()

Laser .

Page Up ()

PU .

Page Down ()

PD .

Menu ()

Menu OSD. Enter [OSD](#).

Zoom In / Out (/) ()

In 32 Out .  
SXGA+ UXGA.









Freeze ()  
Freeze ..

Mute ()  
Mute .

Volume ()  
/.

Keystone ()  
(16)

Enter

- (OSD) .
- OSD OSD computer OSD. video OSD. .
- OSD   OSD.  
: Image-I--> Image-II--> Audio--> Language--> Management--> Image-I .
-     .  
: Brightness--> Color Temp.--> Zoom--> Contrast--> Keystone--> Brightness
- OSD .

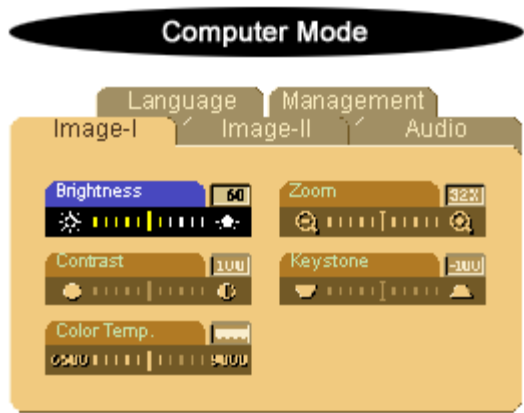

Image-I (-1) ()

Brightness ()

- .

- ⊕ .

Contrast ( )

Contrast .

- ⊖ .
- ⊕ .

.

6500K 9000K 7050K .

Zoom (/)

- ⊕ 32 .
- ⊖ .

Keystone ( )

(16) . ( 16 degrees)

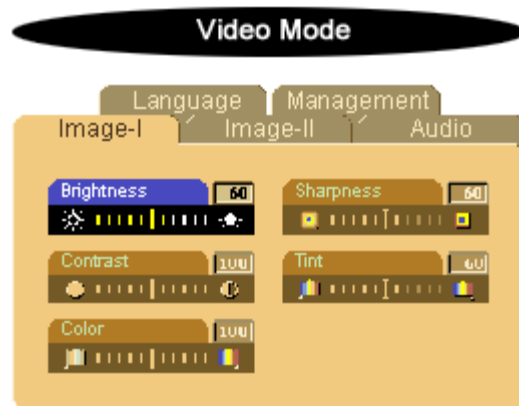

Image-I (-1) ( )

Brightness ( )

.

- ⊖ .
- ⊕ .

Contrast ( )

Contrast .

- ⊖ .
- ⊕ .

Color ( )

- .

- ⊖ .



- ⊕ .

Sharpness ()

- ⊖ .
- ⊕ .

Tint ()

Tint .

- ⊖ .
- ⊕ .

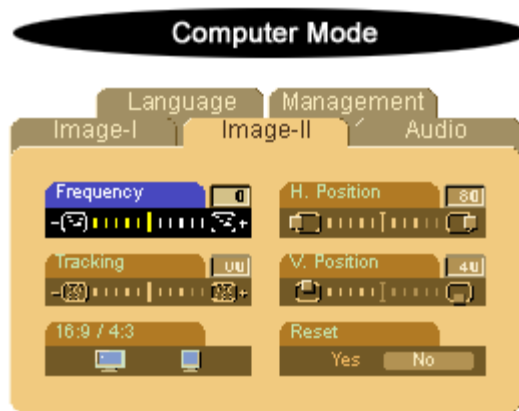

Image-II (-2) ()

Frequency ()

"Frequency" .

Tracking ()

"Tracking" - .

16 : 9 / 4 : 3

Horizontal Position ()

- ⊖ .
- ⊕ .

Vertical Position ()

- ⊖ .
- ⊕ .

Reset ()

Yes t \* Image-I Image-II

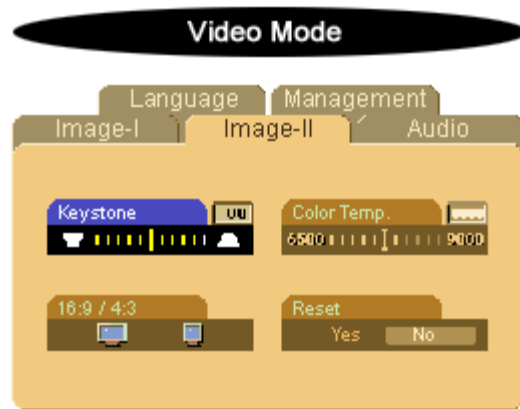

Image-II (-2) ()

Keystone Correction ()

(16)

16 : 9 / 4 : 3

.

.

6500K 9000K 7050K .

Reset ()

Yes \* Image-I Image-II.

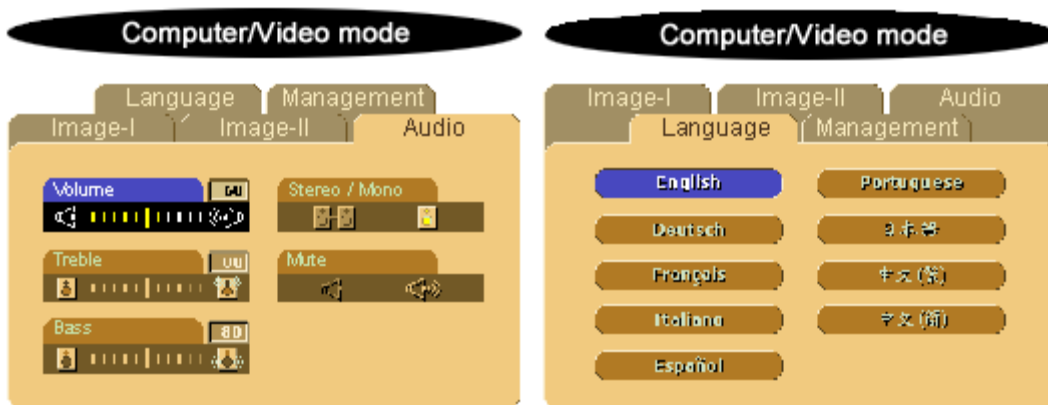



Audio ()

Volume ()

- (-)
- (+)



Treble ()

Treble .

-  .
-  .

Bass ( )

Bass .

-  .
-  .

Stereo / Mono ( / )

- Mono  :
- Stereo  : .

Mute ( )

- :
- :

Language ( )

Language ( )

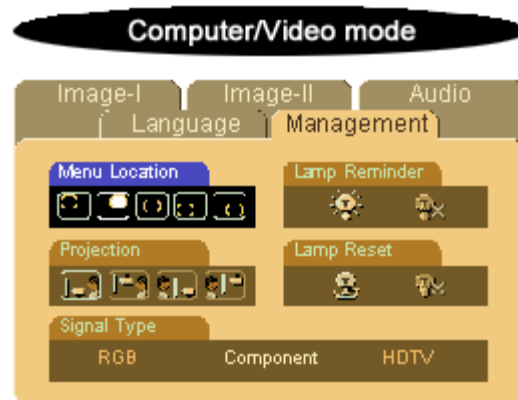

Management ( )

Menu Location ( )

OSD .

Projection ( )

-  Front-Desktop ( )
-  Rear-Desktop ( )
-  Front-Ceiling ( )

-  Rear-Ceiling ()

Signal Type ()

RGB, HDTV Component .

Lamp Reminder ()

Lamp Reminder () Lamp may fail soon! Replacement suggested! ( !) 30 .

Lamp Reset ()

Lamp Reset () Enter .

---

---

: Dell™ 3100MP



[DVD 16:9](#)

, [Dell](#).

---

-  

- "."

- .

- ("").

- .

- R-Sync .

- 1024 x 768 .

- Microsoft® Windows® 95, Windows 98, Windows 2000 Windows XP:

1. Control Panel Display.
2. Settings tab.
3. Desktop Area 1024 x 768.

:

- 1 2 Advanced Properties.
4. Change Monitor.
5. Show all devices. Standard monitor types Manufacturer Models.
6. 1024 x 768.

- :

1. .

2.  

- .

-  

Image-II OSD.

- .

- Image-II OSD.

- .

:

- (Focus Ring) .

- (3.3 [1 .] 39.4 [12 .]) .

DVD 16:9

DVD 16:9 4:3 .

:

- 4:3 DVD DVD 16:9.

- 4:3 DVD 4:3 OSD.

:

- [Management \(\)](#) OSD.

:

- "".



: Dell™ 3100MP

Single Chip DLP™

280:1 (Full On / Full Off)

P-VIP 130

1024 X 768

16.7

F/2.21–2.47, f=28.55–34.28 . 1.2x

21–294 ( )

3.3~39.4 (1~12 )

NTSC,NTSC 4.43,PAL,PAL-M,PAL-N,SECAM HDTV

(1080i,720P, 576P, 480i/P)

Composite Video S-Video

15~100

43~120

2

Universal 100~240 AC 50/60

180

:

: DVI-I 30 //Component HDTV

: D-sub 15

: Composite Video RCA Input S-Video Input

:

3.5 / 1.6 .

2.0 x 6.9 x 8.9 / 52 x 176 x 225 .

: 10°C~ 40°C/50°F~104°F

: 80%

: 20°C~60°C/ -4°F~140°F

: 80%

FCC, CE, VCCI, UL, cUL, TUV GS, ICES-003, MIC, BSMI, C-Tick, NEMKO, GOST, PCBC, CCIB, PSB, EK, EZU, IRAM, NOM

I/O

( x x )

		()		()	
		()	()	()	()
VGA	640X350	70	31.5	70	31.5
VGA	640X350	85	37.9	85	37.9
VGA	640X400	85	37.9	85	37.9
VGA	640X480	60	31.5	60	31.5
VGA	640X480	72	37.9	72	37.9
VGA	640X480	75	37.5	75	37.5
VGA	640X480	85	43.3	85	43.3
VGA	720X400	70	31.5	70	31.5

VGA	720X400	85	37.9	85	37.9
SVGA	800X600	56	35.2	56	35.2
SVGA	800X600	60	37.9	60	37.9
SVGA	800X600	72	48.1	72	48.1
SVGA	800X600	75	46.9	75	46.9
SVGA	800X600	85	53.7	85	53.7
XGA	1024X768	43.4	35.5		
XGA	1024X768	60	48.4	60	48.4
XGA	1024X768	70	56.5	70	56.5
XGA	1024X768	75	60.0	75	60.0
XGA	1024X768	85	68.7	-	-
*SXGA	1280X1024	60	63.98	-	-
*SXGA	1280X1024	75	79.98	-	-
*SXGA	1280X1024	85	91.1	-	-
*SXGA+	1400X1050	60	63.98	-	-
*UXGA	1600X1200	60	75.0	-	-
MAC LC13*	640X480	66.66	34.98	-	-
MAC II 13*	640X480	66.68	35	-	-
MAC 16*	832X624	74.55	49.725	-	-
MAC 19*	1024X768	75	60.24	-	-
*MAC	1152X870	75.06	68.68	-	-
MAC G4	640X480	60	31.35	-	-
MAC G4	640X480	120	68.03	-	-
MAC G4	1024X768	120	97.09	-	-
IMAC DV	640X480	117	60	-	-
IMAC DV	800X600	95	60	-	-
IMAC DV	1024X768	75	60	-	-
IMAC DV	1152X870	75	68.49	-	-
IMAC DV	1280X960	75	75	-	-
IMAC DV	1280X1024	85	91.1	-	-

\*



## Regulatory Notices: Dell™ 3100MP Projector

- [Federal Communications Commission \(FCC\) Notice \(U.S. Only\)](#)
  - [FCC Declaration of Conformity](#)
  - [CE Declaration of Conformity for a Class B Digital Device](#)
  - [Canadian Regulatory Information \(Canada Only\)](#)
  - [EN 55022 Compliance \(Czech Republic Only\)](#)
  - [VCCI Class 2 Notice \(Japan Only\)](#)
  - [MIC Notice \(South Korea Only\)](#)
  - [Polish Center for Testing and Certification Notice](#)
  - [NOM Information \(Mexico Only\)](#)
  - [BSMI Notice \(Taiwan Only\)](#)
  - [Regulatory Listing](#)
- 

### Federal Communications Commission (FCC) Notice (U.S. Only)

 NOTICE: This equipment has been tested and found to comply with the limits for a Class B digital device, pursuant to Part 15 of the FCC Rules. These limits are designed to provide reasonable protection against harmful interference in a residential installation. This equipment generates, uses, and can radiate radio frequency energy and, if not installed and used in accordance with the instructions, may cause harmful interference to radio communications. However, there is no guarantee that interference will not occur in a particular installation. If this equipment does cause harmful interference to radio or television reception, which can be determined by turning the equipment off and on, the user is encouraged to try to correct the interference by one or more of the following measures:

- Reorient or relocate receiving antenna.
- Increase the separation between the equipment and receiver.
- Connect the equipment into an outlet on a circuit different from that to which the receiver is connected.
- Consult the dealer or an experienced radio/TV technician for help.

This device complies with Part 15 of the FCC rules. Operation is subject to the following two conditions:

- This device may not cause harmful interference.
- This device must accept any interference received including interference that may cause undesired operation.

Instructions to Users: This equipment complies with the requirements of FCC (Federal Communication Commission) equipment provided that following conditions are met.

1. Power cable: Shielded power cable must be used.
2. Video inputs: The input signal amplitude must not exceed the specified level.

 NOTICE: Changes or modifications not expressly approved by the party responsible for compliance could void the user's authority to operate the equipment.

---

### FCC Declaration of Conformity

According to 47 CFR, Part 15 of the FCC Rules

\* For the following named product:

DLP Projector  
3100MP/DELL CHC7229

\* Manufactured at:

Coretronic Corporation

We hereby declare that this device complies with Part 15 of the FCC Rules.  
Operation is subject to the following two conditions:

1. This device may not cause harmful interference, and
2. This device must accept any interference received, including interference that may cause undesired operation.

\* FCC Rules:

Tested to comply with FCC part 15, class B

\* Test site at:

Advance Data Technology Corporation  
No.81-1, Lu Liao Keng, 9 Ling, Wu Lung Tsung, Chiung Lin Hsiang, Hsin Chu  
Hsien, Taiwan

\* Responsible Party for  
Product Compliance:

Coretronic Corporation  
No 11, Li Hsing Rd, Scienced-Based Industrial Park, Hsinchu, Taiwan  
Tel: 886-3-5772000 Fax: 886-3-5790066

\* Manufacturer Information:

Coretronic Corporation  
No 11, Li Hsing Rd, Scienced  
based Industrial Park, Hsinchu,  
300, Taiwan

RD Center  
Technology Engineering  
Associate Vice President

March 29, 2002

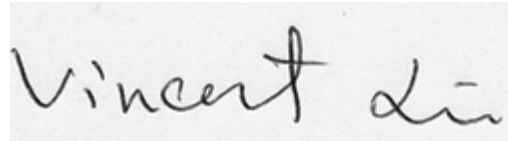

Hsinchu, March 29, 2002

Mr. Vincent Lin

---

## CE Declaration of Conformity for a Class B Digital Device

Directives to which conformity is declared:

EMC Directives 89/336/EEC and Amending Directive 92/31/EEC

And

Low Voltage Directive 73/23/EEC

Standards to which conformity is declared

EN55022: 1998; EN55024: 1998; EN60950 +A1+A2+A3+A4: 1992;

EN61000-3-2: 1995; EN61000-3-3: 1995

Manufacturer's Name: Coretronic Corporation

Manufacturer's Address: No 11, Li Hsing Rd, Scienced-Based Industrial Park, Hsinchu, Taiwan

Importer's Address:

Dell Computer de Mexico,  
Paseo de la Reforma 2620, 11th Floor  
Col. Lomas Altas Dell Product  
Mexico DF  
CP 11950

Type of Equipment: DLP Projector

Model Number(s): 3100MP

Reference Report Number:

Previously Declared Models:

I, the undersigned, hereby declare that the equipment specified above conforms to the above Directive(s) and standards.

Hsinchu, Taiwan

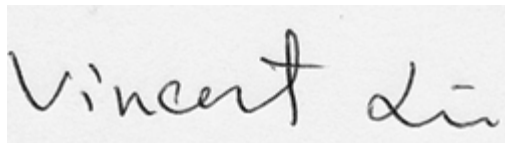

March 29, 2002

Mr. Vincent Lin

Head of RD Center

---

### Canadian Regulatory Information (Canada Only)

This digital apparatus does not exceed the Class B limits for radio noise emissions from digital apparatus set out in the Radio Interference Regulations of the Canadian Department of Communications.

Note that Canadian Department of Communications (DOC) regulations provide, that changes or modifications not expressly approved by Dell Computer Corporation could void your authority to operate this equipment.

This Class B digital apparatus meets all requirements of the Canadian Interference-Causing Equipment Regulations.

Cet appareil numerique de la classe B respecte toutes les exigences du Reglement sur le materiel brouilleur du Canada.

---

### EN 55022 Compliance (Czech Republic Only)

This device belongs to Class B devices as described in EN 55022, unless it is specifically stated that it is a Class A device on the specification label. The following applies to devices in Class A of EN 55022 (radius of protection up to 30 meters). The user of the device is obliged to take all steps necessary to remove sources of interference to telecommunication or other devices.

**Pokud není na typovém štítku počítače uvedeno, že spadá do třídy A podle EN 55022, spadá automaticky do třídy B podle EN 55022. Pro zařízení zařazená do třídy A (ochranné pásmo 30m) podle EN 55022 platí následující. Dojde-li k rušení telekomunikačních nebo jiných zařízení, je uživatel povinen provést taková opatření, aby rušení odstranil.**

---

### VCCI Class 2 Notice (Japan Only)

This equipment complies with the limits for a Class 2 digital device (devices used in or adjacent to a residential environment) and conforms to the standards for information technology equipment that are set by the Voluntary Control Council for Interference for preventing radio frequency interference in residential areas.



Class B ITE

この装置は、情報処理装置等電波障害自主規制協議会 (VCCI) の基準に基づくクラス B 情報技術装置です。この装置は家庭環境で使用することを目的としていますが、ラジオやテレビジョン受信機に近接して使用されると、受信障害を引き起こすことがあります。取扱説明書に従って正しい取り扱いをしてください。

---

## MIC Notice (South Korea Only)

B Class Device



1. 기기의 명칭(모델명) :
2. 인증번호 :
3. 인증받은 자의 상호 : (B)
4. 제조년월일:
5. 제조자/제조국가 :

기종별	사용자 안내문
B급 기기 (가정용 정보통신기기)	이 기기는 가정용으로 전자파적합등록을 한 기기로서 주거지역에서는 물론 모든 지역에서 사용할 수 있습니다.

Please note that this device has been approved for nonbusiness purposes and may be used in any environment, including residential areas.

---

## Polish Center for Testing and Certification Notice

The equipment should draw power from a socket with an attached protection circuit (a three-prong socket). All equipment that works together (computer, monitor, printer, and so on) should have the same power supply source.

The phasing conductor of the room's electrical installation should have a reserve short-circuit protection device in the form of a fuse with a nominal value no larger than 16 amperes (A).

To completely switch off the equipment, the power supply cable must be removed from the power supply socket, which should be located near the equipment and easily accessible.

A protection mark "B" confirms that the equipment is in compliance with the protection usage requirements of standards PN-93/T-42107 and PN-89/E-06251.

# **Wymagania Polskiego Centrum Badań i Certyfikacji**

Urządzenie powinno być zasilane z gniazda z przyłączonym obwodem ochronnym (gniazdo z kołkiem). Współpracujące ze sobą urządzenia (komputer, monitor, drukarka) powinny być zasilane z tego samego źródła.

Instalacja elektryczna pomieszczenia powinna zawierać w przewodzie fazowym rezerwową ochronę przed zwarciami, w postaci bezpiecznika o wartości znamionowej nie większej niż 16A (amperów).

W celu całkowitego wyłączenia urządzenia z sieci zasilania, należy wyjąć wtyczkę kabla zasilającego z gniazdka, które powinno znajdować się w pobliżu urządzenia i być łatwo dostępne.

Znak bezpieczeństwa "B" potwierdza zgodność urządzenia z wymaganiami bezpieczeństwa użytkowania zawartymi w PN-93/T-42107 i PN-EN 55022:1996.

Jeżeli na tabliczce znamionowej umieszczono informację, że urządzenie jest klasy A, to oznacza to, że urządzenie w środowisku mieszkalnym może powodować zakłócenia radioelektryczne. W takich przypadkach można żądać od jego użytkownika zastosowania odpowiednich środków zaradczych.

## **Pozostałe instrukcje bezpieczeństwa**

- Nie należy używać wtyczek adapterowych lub usuwać kołka obwodu ochronnego z wtyczki. Jeżeli konieczne jest użycie przedłużacza to należy użyć przedłużacza 3-żyłowego z prawidłowo połączonym przewodem ochronnym.
- System komputerowy należy zabezpieczyć przed nagłymi, chwilowymi wzrostami lub spadkami napięcia, używając eliminatora przepięć, urządzenia dopasowującego lub bezzakłócenowego źródła zasilania.
- Należy upewnić się, aby nic nie leżało na kablach systemu komputerowego, oraz aby kable nie były umieszczone w miejscu, gdzie można byłoby na nie nadeptywać lub potykać się o nie.
- Nie należy rozlewać napojów ani innych płynów na system komputerowy.
- Nie należy wpychać żadnych przedmiotów do otworów systemu komputerowego, gdyż może to spowodować pożar lub porażenie prądem, poprzez zwarcie elementów wewnętrznych.
- System komputerowy powinien znajdować się z dala od grzejników i źródeł ciepła. Ponadto, nie należy blokować otworów wentylacyjnych. Należy unikać kładzenia luźnych papierów pod komputer oraz umieszczania komputera w ciasnym miejscu bez możliwości cyrkulacji powietrza wokół niego.

---

## **NOM Information (Mexico Only)**

The following information is provided on the device(s) described in this document in compliance with the requirements of the official Mexican standards (NOM)

Exporter:	Dell Computer Corporation One Dell Way Round Rock, TX 78682
Importer:	Dell Computer de México, Paseo de la Reforma 2620, 11th Floor Col. Lomas Altas México DF CP 11950
Ship to:	Dell Computer de Mexico, S.A. de C.V. al Cuidado de Kuehne & Nagel de México S. de R.I., Avenida Soles No. 55 Col. Peñon de los Baños, 15520 Mexico, D.F.

Supply voltage: > 100–240 VAC  
Frequency: 50–60 Hz  
Current consumption: 1.2 A

---

## BSMI Notice (Taiwan Only)

### 警告使用者：

這是甲類的資訊產品，在居住的環境中使用時，可能會造成射頻干擾，在這種情況下，使用者會被要求採取某些適當的對策。

## Regulatory Listing

### Safety Certifications:

- UL 1950
- cUL
- NOM
- CE Mark--EN60950: 1992 + A1 + A2 + A3
- NEMKO
- SEMKO
- DEMKO
- FIMKO
- EZU
- IEC 950
- TUV GS
- PCBC
- GOST
- CCIB
- EK
- PSB
- IRAM

### EMC Certifications:

- FCC Part 15 Class B
  - CE Mark--EN55022:1998 Class B, EN61003-3:1995, EN55024:1998
  - ICES-003
  - EZU
  - NEMKO
  - SEMKO
  - DEMKO
  - FIMKO
  - PCBC
  - C-Tick
  - VCCI Class B ITE
  - MIC
  - BSMI
-

[Back to Contents Page](#)

# Dell: Dell™ 3100MP



Dell "" "" , "-" "-" ()

() ", "

:

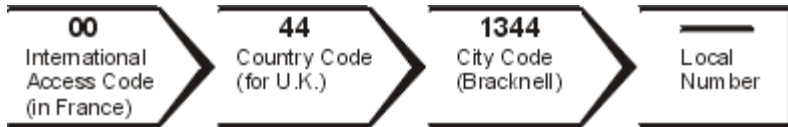

:



: () —

**(Express Service Code) Dell**

()			
<a href="#">Argentina</a> (Buenos Aires)	00	54	11
<a href="#">Australia</a> (Sydney)	0011	61	2
<a href="#">Austria</a> (Vienna)	900	43	1
<a href="#">Belgium</a> (Brussels)	00	32	2
<a href="#">Brazil</a>	0021	55	51
<a href="#">Brunei</a>	—	673	—
<a href="#">Canada</a> (North York, Ontario)	011	—	Not required



<a href="#">Chile</a> (Santiago)	—	56	2
<a href="#">China</a> (Xiamen)	—	86	592
<a href="#">Czech Republic</a> (Prague)	00	420	2
<a href="#">Denmark</a> (Horsholm)	00	45	Not required
<a href="#">Finland</a> (Helsinki)	990	358	9
<a href="#">France</a> (Paris) (Montpellier)	00	33	(1) (4)
<a href="#">Germany</a> (Langen)	00	49	6103
<a href="#">Hong Kong</a>	001	852	Not required
<a href="#">Ireland</a> (Cherrywood)	16	353	1
<a href="#">Italy</a> (Milan)	00	39	02
<a href="#">Japan</a> (Kawasaki)	001	81	44
<a href="#">Korea</a> (Seoul)	001	82	2
<a href="#">Luxembourg</a>	00	352	—
<a href="#">Macau</a>	—	853	Not required
<a href="#">Malaysia</a> (Penang)	00	60	4
<a href="#">Mexico</a> (Colonia Granada)	00	52	Not required
<a href="#">Netherlands</a> (Amsterdam)	00	31	20
<a href="#">New Zealand</a>	00	64	—
<a href="#">Norway</a> (Lysaker)	00	47	Not required
<a href="#">Poland</a> (Warsaw)	011	48	22
<a href="#">Portugal</a>	00	35	—
<a href="#">Singapore</a> (Singapore)	005	65	Not required
<a href="#">South Africa</a> (Johannesburg)	09/091	27	11
<a href="#">Spain</a> (Madrid)	00	34	91
<a href="#">Sweden</a> (Upplands Vasby)	00	46	8
<a href="#">Switzerland</a> (Geneva)	00	41	22
<a href="#">Taiwan</a>	002	886	—
<a href="#">Thailand</a>	001	66	—
<a href="#">U.K.</a> (Bracknell)	010	44	1344
<a href="#">U.S.A.</a> (Austin, Texas)	011	1	Not required

0			
Antigua and Barbuda	General Support		1-800-805-5924
Argentina (Buenos Aires)	Technical Support, Customer Care		toll free: 0800 444 0733
	Sales		toll free: 0810 444 3355
	Tech Support Fax	11	4515-7139
	Customer Care Fax	11	4515-7139
	Website: <a href="http://www.dell.com.ar">www.dell.com.ar</a>		
Barbados	General Support		1-800-534-3066
Bermuda	General Support		1-800-342-0671
Brazil	Customer Support, Technical Support		toll free: 0800 90 3355
	Technical Support Fax	51	481-5470
	Customer Care Fax	51	481-5480
	Sales		toll free: 0800 90 3390
	Website: <a href="http://www.dell.com/br">www.dell.com/br</a>		
Canada (North York, Ontario)	Automated Order-Status System		toll free: 1-800-433-9014
	AutoTech (Automated technical support)		toll free: 1-800-247-9362
	Customer Care (From outside Toronto)		toll free: 1-800-387-5759
	Customer Care (From within Toronto)	416	758-2400
	Customer Technical Support		toll free: 1-800-847-4096
	Sales (Direct sales—from outside Toronto)		toll free: 1-800-387-5752
	Sales (Direct sales—from within Toronto)	416	758-2200
	Sales (Federal government, education,		toll free: 1-800-567-7542

	and medical)		
	Sales (Major accounts)		toll free: 1-800-387-5755
	TechFax		toll free: 1-800-950-1329
Cayman Islands	General Support		1-800-805-7541
Chile (Santiago)  <i>NOTE: Customers in Chile call the U.S.A. for sales, customer, and technical assistance</i>	Sales, Customer Support, and Technical Support		toll free: 1230-020-4823
Colombia	General Support		980-9-15-3978
Costa Rica	General Support		800-012-0435
Dominican Republic	General Support		1-800-148-0530
El Salvador	General Support		01-889-753-0777
Guatemala	General Support		1-800-999-0136
Jamaica	General Support		1-800-682-3639

Latin America <i>NOTE: Customers in Latin America call the U.S.A. for sales, customer, and technical assistance.</i>	Customer Technical Support (Austin, Texas, U.S.A.)	512	728-4093
	Customer Service (Austin, Texas, U.S.A.)	512	728-3619
	Fax (Technical Support and Customer Service) (Austin, Texas, U.S.A.)	512	728-3883
	Sales (Austin, Texas, U.S.A.)	512	728-4397
	SalesFax (Austin, Texas, U.S.A.)	512	728-4600 728-3772
Mexico	Customer Technical Support		001-877-384-8979 or 001-877-269-3383
	Sales		50-81-8800 or 01-800-888-3355
	Customer Service		001-877-384-8979 or 001-877-269-3383
	Main		50-81-8800 or 01-800-888-3355
Netherlands Antilles	General Support		001-800-882-15194
Nicaragua	General Support		001-800-220-1006
Panama	General Support		001-800-507-0962
Peru	General Support		0800-50-669
Puerto Rico	General Support		800-805-7545

St. Lucia	General Support		1-800-882-1521
Trinidad and Tobago	General Support		1-800-805-8035
U.S.A. (Austin, Texas)	Automated Order-Status System		toll free: 1-800-433-9014
	AutoTech (For portable and desktop computers)		toll free: 1-800-247-9362
	Dell Home and Small Business Group (For portable and desktop computers):		
	Customer Technical Support (Return Material Authorization Numbers)		toll free: 1-800-624-9896
	Customer Technical Support (Home sales purchased via www.dell.com)		toll free: 1-877-576-3355
	Customer Service (Credit Return Authorization Numbers)		toll free: 1-800-624-9897
	National Accounts (Systems purchased by established Dell national accounts [have your account number handy] or value-added resellers [VARs]):		
	Customer Service and Technical Support (Return Material Authorization Numbers)		toll free: 1-800-822-8965
	Public Americas (Systems purchased by governmental agencies [local, state, or federal], medical institutions, or educational institutions):		
	Customer Service and Technical Support (Return Material Authorization Numbers)		toll free: 1-800-234-1490
	Dell Sales		toll free: 1-800-289-3355 toll free: 1-800-879-3355
	Spare Parts Sales		toll free: 1-800-357-3355
	Desktop and Portable Fee-Based Technical Support		toll free: 1-800-433-9005
	Sales (Catalogs)		toll free: 1-800-426-5150
	Fax		toll free: 1-800-727-8320
	TechFax		toll free: 1-800-950-1329
Dell Services for the Deaf, Hard-of-Hearing, or Speech-Impaired		toll free: 1-877-DELLTTY (1-877-335-5889)	

	Switchboard	512	338-4400
U.S. Virgin Islands	General Support		1-877-673-3355
Venezuela	General Support		8001-3605

0			
Austria (Vienna)  <i>NOTE: Customers in Austria call Langen, Germany for Technical Support and Customer Care.</i>	Switchboard	01	491 040
	Home/Small Business Sales	01	795676-02
	Home/Small Business Sales Fax	01	795676-05
	Home/Small Business Customer Care	01	795676-03
	Preferred Accounts/Corporate Customer Care		0660-8056
	Home/Small Business Technical Support	01	795676-04
	Preferred Accounts/Corporate Technical Support		0660-8779
	Website: support.euro.dell.com		
	E-mail: tech_support_central_europe@dell.com		
Belgium (Brussels)	Technical Support	02	481 92 88
	Customer Care	02	481 91 19
	Home/Small Business Sales		toll free: 0800 16884
	Corporate Sales	02	481 91 00

	Fax	02	481 92 99
	Switchboard	02	481 91 00
	Website: support.euro.dell.com		
	E-mail: tech_be@dell.com		
	E-mail for French Speaking Customers: support.euro.dell.com/be/fr/emaildell/		
Czech Republic (Prague)	Technical Support	02	22 83 27 27
	Customer Care	02	22 83 27 11
	Fax	02	22 83 27 14
	TechFax	02	22 83 27 28
	Switchboard	02	22 83 27 11
	Website: support.euro.dell.com		
	E-mail: czech_dell@dell.com		
Denmark (Horsholm)  <i>NOTE: Customers in Denmark call Sweden for fax technical support.</i>	Technical Support		45170182
	Relational Customer Care		45170184
	Home/Small Business Customer Care		32875505
	Switchboard		45170100
	Fax Technical Support (Upplands Vasby, Sweden)	46	859005594
	Fax Switchboard		45170117
	Website: support.euro.dell.com		
	E-mail: den_support@dell.com  E-mail Support for Servers: Nordic_server_support@dell.com		
Finland (Helsinki)	Technical Support	09	253 313 60
	Technical Support Fax	09	253 313 81
	Relational Customer Care	09	253 313 38
	Home/Small Business Customer Care	09	693 791 94
	Fax	09	253 313 99
	Switchboard	09	253 313 00
	Website: support.euro.dell.com		
	E-mail: fin_support@dell.com		

France (Paris) (Montpellier)	Home and Small Business		
	Technical Support	0825	387 270
	Customer Care	0825	823 833
	Fax	0825	004 701
	Fax (Alternative)	04	99 75 40 01
	Switchboard	0825	004 700
	Switchboard (Alternative)	04	99 75 40 00
	Sales	0825	004 700
	Website: support.euro.dell.com		
	E-mail: support.euro.dell.com/fr/fr/emaildell/		
	Corporate		
	Technical Support	0825	004 719
	Customer Care	0825	338 339
	Fax	01	55 94 71 01
	Switchboard	01	55 94 71 00
	Sales	01	55 94 71 00
	Website: support.euro.dell.com		
	E-mail: support.euro.dell.com/fr/fr/emaildell/		
	Germany (Langen)	Technical Support	06103
Home/Small Business Customer Care			0180-5-224400
Global Segment Customer Care		06103	766-9570
Preferred Accounts Customer Care		06103	766-9420
Large Accounts Customer Care		06103	766-9560
Public Accounts Customer Care		06103	766-9555
Switchboard		06103	766-7000
Website: support.euro.dell.com			
E-mail: tech_support_central_europe@dell.com			
Ireland (Cherrywood)	Ireland Technical Support	1850	543 543
	UK Technical Support (dial number within UK only)	0870	908 0800



	Ireland Home User Customer Care	01	204 4095
	Ireland Small Business Customer Care	01	204 4444
	Ireland Corporate Customer Care	01	204 4003
	UK Customer Care (dial number within UK only)	0870	906 0010
	Ireland Sales	01	204 4444
	UK Sales (dial number within UK only)	0870	907 4000
	SalesFax	01	204 0144
	Ireland Fax	01	204 5960
	Switchboard	01	204 4444
	Website: support.euro.dell.com		
	E-mail: dell_direct_support@dell.com		
Italy (Milan)	Home and Small Business		
	Technical Support	02	577 826 90
	Customer Care	02	696 821 14
	Fax	02	696 821 13
	Switchboard	02	696 821 11
	Website: support.euro.dell.com		
	E-mail: support.euro.dell.com/it/it/emaildell/		
	Corporate		
	Technical Support	02	577 826 90
	Customer Care	02	577 825 55
	Fax	02	035 30
	Switchboard	02	577 821
	Website: support.euro.dell.com		
	E-mail: support.euro.dell.com/it/it/emaildell/		
Luxembourg	Technical Support (Brussels, Belgium)	02	481 92 88
	Home/Small Business Sales (Brussels, Belgium)		toll free: 080016884
<i>NOTE: Customers in Luxembourg call Belgium for</i>			

<i>sales, customer, and technical assistance.</i>	Corporate Sales (Brussels, Belgium)	02	481 91 00
	Customer Care (Brussels, Belgium)	02	481 91 19
	Switchboard (Brussels, Belgium)	02	481 91 00
	Fax (Brussels, Belgium)	02	481 92 99
	Website: support.euro.dell.com		
	E-mail: tech_be@dell.com		
Netherlands (Amsterdam)	Technical Support	020	581 8838
	Customer Care	020	581 8740
	Home/Small Business Sales		toll free: 0800-0663
	Home/Small Business Sales Fax	020	682 7171
	Corporate Sales	020	581 8818
	Corporate Sales Fax	020	686 8003
	Fax	020	686 8003
	Switchboard	020	581 8818
	Website: support.euro.dell.com		
	E-mail: tech_nl@dell.com		
Norway (Lysaker)  <i>NOTE: Customers in Norway call Sweden for fax technical support.</i>	Technical Support		671 16882
	Relational Customer Care		671 17514
	Home/Small Business Customer Care		231 62298
	Switchboard		671 16800
	Fax Technical Support (Upplands Vasby, Sweden)	00	46 08 590 05 594
	Fax Switchboard		671 16865
	Website: support.euro.dell.com		
	E-mail: nor_support@dell.com  E-mail Support for Servers: Nordic_server_support@dell.com		
Poland (Warsaw)	Customer Service Phone	22	57 95 700
	Customer Care	22	57 95 999
	Sales	22	57 95 999
	Switchboard	22	57 95 999

	Customer Service Fax	22	57 95 806
	Fax	22	57 95 998
	Website: support.euro.dell.com		
	E-mail: pl_support@dell.com		
Portugal	Technical Support	35	800 834 077
	Customer Care		800 300 415 or 800 834 075
	Sales		800 300 410 or 800 300 411 or 800 300 412 or 351 214 220 710
	Switchboard	34	917 229 200
	Fax	35	121 424 01 12
	E-mail: support.euro.dell.com/es/es/emaildell/		
Spain (Madrid)	Home and Small Business		
	Technical Support		902 100 130
	Customer Care		902 118 540
	Sales		902 118 541
	Fax		902 118 539
	Website: support.euro.dell.com		
	E-mail: support.euro.dell.com/es/es/emaildell/		
	Corporate		
	Technical Support		902 100 130
	Customer Care		902 118 546
	Switchboard	91	722 92 00
	Fax	91	722 95 83
	Website: support.euro.dell.com		
	E-mail: support.euro.dell.com/es/es/emaildell/		
Sweden (Upplands Vasby)	Technical Support	08	590 05 199
	Relational Customer Care	08	590 05 642

	Home/Small Business Customer Care	08	587 70 527
	Fax Technical Support	08	590 05 594
	Sales	08	590 05 185
	Website: support.euro.dell.com		
	E-mail: swe_support@dell.com		
Switzerland (Geneva)	Technical Support (Home and Small Business)		0844 811 411
	Technical Support (Corporate)		0844 822 844
	Customer Care (Home and Small Business)		0848 802 202
	Customer Service (Corporate)		0848 821 721
	Switchboard	022	799 01 01
	Fax	022	799 01 90
	Website: support.euro.dell.com		
	E-mail for French Speaking HSB and Corporate Customers: support.euro.dell.com/ch/fr/emaildell/		
U.K. (Bracknell)	Technical Support (Corporate/Preferred Accounts/PAD [1000+ employees])	0870	908 0500
	Technical Support (Direct/PAD and general)	0870	908 0800
	Global Accounts Customer Care	01344	373 186
	Corporate Customer Care	0870	908 0500
	Preferred Accounts (500–5000 employees) Customer Care	01344	373 196
	Central Government Customer Care	01344	373 193
	Local Government Customer Care	01344	373 199
	Home/Small Business Sales	0870	907 4000
	Home/Small Business Customer Care	0870	906 0010

Corporate/Public Sector Sales	01344	860 456
Website: support.euro.dell.com		
E-mail: dell_direct_support@dell.com		

0			
Australia (Sydney)	Home and Small Business		1-300-65-55-33
	Government and Business		toll free: 1-800-633-559
	Preferred Accounts Division (PAD)		toll free: 1-800-060-889
	Customer Care		toll free: 1-800-819-339
	Corporate Sales		toll free: 1-800-808-385
	Transaction Sales		toll free: 1-800-808-312
	Fax		toll free: 1-800-818-341
Brunei <i>NOTE: Customers in Brunei call Malaysia for customer assistance.</i>	Customer Technical Support (Penang, Malaysia)		633 4966
	Customer Service (Penang, Malaysia)		633 4949
	Transaction Sales (Penang, Malaysia)		633 4955
China (Xiamen)	Home and Small Business Technical Support		toll free: 800 858 2437
	Corporate Accounts Technical Support		toll free: 800 858 2333
	Customer Experience		toll free: 800 858 2060
	Home and Small Business		toll free: 800 858 2222
	Preferred Accounts Division		toll free: 800 858 2062
	Large Corporate Accounts North		toll free: 800 858 2999
	Large Corporate Accounts East		toll free: 800 858 2020
	Large Corporate Accounts South		toll free: 800 858 2355
	Large Corporate Accounts GCP		toll free: 800 858 2055
	Large Corporate Accounts HK		toll free: 800 964108
	Large Corporate Accounts GCP HK		toll free: 800 907308

Hong Kong <i>NOTE: Customers in Hong Kong call Malaysia for customer assistance.</i>	Technical Support		toll free: 800 96 4107
	Customer Service (Penang, Malaysia)		633 4949
	Transaction Sales		toll free: 800 96 4109
	Corporate Sales		toll free: 800 96 4108
India	Technical Support		1600-33-8045
	Sales		1600-33-8044
Japan (Kawasaki)	Technical Support	044	toll free: 0120-1982-26 or toll free: 0120-1984-33
	Technical Support Outside of Japan	044	520-1435 or 556-3894
	Customer Care	044	556-4240
	24-Hour Automated Order Status Service	044	556-3801
	Individual User	044	556-1657
	Business Sales Division (Up to 400 employees)	044	556-3494
	Public Sales (Government agencies, education institutions, and medical institutions)	044	556-3440
	Preferred Accounts Division Sales (Over 400 employees)	044	556-3433
	Global Segment Japan	044	556-3469
	Large Corporate Accounts Sales (Over 3500 employees)	044	556-3440
	Faxbox Service	044	556-3490
	Switchboard	044	556-4300
	Web site: <a href="http://support.jp.dell.com">support.jp.dell.com</a>		
	Korea (Seoul)	Technical Support	
Sales			toll free: 080-200-3600
Customer Service (Penang, Malaysia)			toll free: 604-633-4949
Customer Service (Seoul, Korea)			080-200-3800
Fax			2194-6202

	Switchboard		2194-6000
Macau <i>NOTE: Customers in Macau call Malaysia for customer assistance.</i>	Technical Support		toll free: 0800 582
	Customer Service (Penang, Malaysia)		633 4949
	Transaction Sales		toll free: 0800 581
Malaysia (Penang)	Technical Support		toll free: 1 800 888 298
	Customer Service	04	633 4949
	Transaction Sales		toll free: 1 800 888 202
	Corporate Sales		toll free: 1 800 888 213
New Zealand	Home and Small Business		0800 446 255
	Government and Business		0800 444 617
	Sales		0800 441 567
	Fax		0800 441 566
Singapore (Singapore) <i>NOTE: Customers in Singapore call Malaysia for customer assistance.</i>	Technical Support		toll free: 800 6011 051
	Customer Service (Penang, Malaysia)	04	633 4949
	Transaction Sales		toll free: 800 6011 054
	Corporate Sales		toll free: 800 6011 053
South Africa (Johannesburg)	Technical Support	011	709 7710
	Customer Care	011	709 7707
	Sales	011	709 7700
	Fax	011	706 0495
	Switchboard	011	709 7700
	Website: support.euro.dell.com		
	E-mail: dell_za_support@dell.com		
Southeast Asian/Pacific Countries (excluding Australia, Brunei, China, Hong Kong, Japan, Korea, Macau, Malaysia, New Zealand,	Customer Technical Support, Customer Service, and Sales (Penang, Malaysia)		60 4 633-4810

Singapore, Taiwan, and Thailand—refer to individual listings for these countries)			
Taiwan	Technical Support		toll free: 0080 60 1225
	Technical Support (Servers)		toll free: 0080 60 1256
	Customer Service (Penang, Malaysia)		633 4949
	Transaction Sales		toll free: 0080 651 228/0800 33 556
	Corporate Sales		toll free: 0080 651 227/0800 33 555
Thailand  <i>NOTE: Customers in Thailand call Malaysia for customer assistance.</i>	Technical Support		toll free: 088 006 007
	Customer Service (Penang, Malaysia)		633 4949
	Sales		toll free: 088 006 009